

# HDM500 SERIES | HIGH DENSITY

500W Medical AC-DC Power Supply

MODEL: HDM500 | CATEGORY: AC-DC | RATED POWER: 500W | FORM: FLEXIBLE

## PRODUCT OVERVIEW



### Key Product Features

- Universal 90-264 VAC input range
- Operating altitude up to 5000m
- Built-in 12V/0.3A Auxiliary Output, Standby 5V @ 1A with Fan / 0.4A without Fan
- Current Share Function Optional (except 115 models)
- High Efficiency up to 93%.4000VAC input-to-output isolation
- Remote ON/OFF Function
- 240 Watt with Free Air Convection
- 500 Watt with 30CFM FAN
- Active PFC, PF > 0.94

## PRODUCT DESCRIPTION

Digital Power's HDM500 Series are switching power supplies that produce superior output wattages with natural convection. The series include enclosed, open frame and U bracket format with output voltage options of 12V, 15V, 24V and 48V. Featured with compact, low profile footprint, and best-in-class performance, HDM500 Series are optimal for ITE and Medical Applications. Designed with energy saving in mind, Digital Power's HDM500 Series boasts not only high operating efficiency up to 93%, but also high-power density with full input range of 90-264VAC. The series is especially suited for medical and healthcare electronics where isolation, leakage current, EMC behavior, and long-term reliability are central design requirements.

## SAFETY CERTIFICATES

- Medical Certification: Certified to UL / IEC / EN 60601-1 Edition 3.1
- Insulation Class: Features 2MOPP (Means of Patient Protection) insulation.
- Agency Marks: cURus, CE, and CB certified (File E199779 and E308218).
- Fusing Safety: Features double pole, neutral fusing.

## APPLICATIONS

- Medical carts and clinical workstations
- Diagnostic and monitoring equipment
- Patient-adjacent healthcare electronics
- Laboratory instruments and analyzers
- Dental, therapy, and treatment devices

# ELECTRICAL SPECIFICATIONS

## MODEL INFORMATION

Parameter	HDM5000-112	HDM5000-115	HDM5000-124	HDM5000-148
Format / Type	Open Frame	Open Frame	Open Frame	Open Frame
Output Voltage (V.DC.)	12V	15V	24V	48V
Max Output Wattage	500 W (30CFM FAN); 230 W (115 VAC) / 240 W (230 VAC)	500 W (30CFM FAN); 210 W (115 VAC) / 220 W (230 VAC)	500 W (30CFM FAN); 230 W (115 VAC) / 240 W (230 VAC)	500 W (30CFM FAN); 230 W (115 VAC) / 240 W (230 VAC)
Max Current (30CFM FAN)	41.5 A	33.3 A	20.8 A	10.41 A
Max Current (Free Air, 115 VAC)	19.16 A	14 A	9.58 A	4.8 A
Max Current (Free Air, 230 VAC)	20 A	14.66 A	10 A	5 A
Max Capacitive Load	5,000 $\mu$ F	3,750 $\mu$ F	2,500 $\mu$ F	1,250 $\mu$ F
Ripple & Noise (typ.) (Note 1)	160mV	160mV	240mV	480mV
Efficiency (at 230 VAC)	90.5%	90.5%	92%	93%
Dimensions (L x W x H)	5.03 x 3.0 x 1.38 Inches (127.8 x 76.2 x 35.0 mm)	5.03 x 3.0 x 1.38 Inches (127.8 x 76.2 x 35.0 mm)	5.03 x 3.0 x 1.38 Inches (127.8 x 76.2 x 35.0 mm)	5.03 x 3.0 x 1.38 Inches (127.8 x 76.2 x 35.0 mm)
Weight	480 g	480 g	480 g	480 g

Parameter	HDM500U-112	HDM500U-115	HDM500U-124	HDM500U-148
Format / Type	U Bracket	U Bracket	U Bracket	U Bracket
Output Voltage (V.DC.)	12V	15V	24V	48V
Max Output Wattage	500 W (30CFM FAN); 190 W (115 VAC) / 200 W (230 VAC)	500 W (30CFM FAN); 170 W (115 VAC) / 180 W (230 VAC)	500 W (30CFM FAN); 190 W (115 VAC) / 200 W (230 VAC)	500 W (30CFM FAN); 190 W (115 VAC) / 200 W (230 VAC)
Max Current (30CFM FAN)	41.5 A	33.3 A	20.8 A	10.41 A
Max Current (Free Air, 115 VAC)	15.83 A	11.33 A	7.91 A	3.96 A
Max Current (Free Air, 230 VAC)	16.6 A	12 A	8.33 A	4.17 A
Max Capacitive Load	5,000 $\mu$ F	3,750 $\mu$ F	2,500 $\mu$ F	1,250 $\mu$ F
Ripple & Noise (typ.) (Note 1)	160mV	160mV	240mV	480mV
Efficiency (at 230 VAC)	90.5%	90.5%	92%	93%
Dimensions (L x W x H)	5.5 x 3.25 x 1.6 Inches (139.7 x 82.55 x 40.6 mm)	5.5 x 3.25 x 1.6 Inches (139.7 x 82.55 x 40.6 mm)	5.5 x 3.25 x 1.6 Inches (139.7 x 82.55 x 40.6 mm)	5.5 x 3.25 x 1.6 Inches (139.7 x 82.55 x 40.6 mm)
Weight	580 g	580 g	580 g	580 g

For quotes and customization requests, contact Digital Power sales at (877) 634-0982 or sales@digipwr.com.

# ELECTRICAL SPECIFICATIONS

## MODEL INFORMATION

Parameter	HDM500E-112	HDM500E-115	HDM500E-124	HDM500E-148
Format / Type	Enclosed	Enclosed	Enclosed	Enclosed
Output Voltage (V.DC.)	12V	15V	24V	48V
Max Output Wattage	500 W	500 W	500 W	500 W
Max Current	41.5 A	33.3 A	20.8 A	10.41 A
Max Capacitive Load	5,000 $\mu$ F	3,750 $\mu$ F	2,500 $\mu$ F	1,250 $\mu$ F
Ripple & Noise (typ.) (Note 1)	160mV	160mV	240mV	480mV
Efficiency (at 230 VAC)	89%	89%	91%	92%
Dimensions (L x W x H)	5.5 x 3.25 x 2.42 Inches (139.7 x 82.55 x 61.4 mm)	5.5 x 3.25 x 2.42 Inches (139.7 x 82.55 x 61.4 mm)	5.5 x 3.25 x 2.42 Inches (139.7 x 82.55 x 61.4 mm)	5.5 x 3.25 x 2.42 Inches (139.7 x 82.55 x 61.4 mm)
Weight	690 g	690 g	690 g	690 g

## SPECIFICATION INFORMATION

[INPUT]	Value
Voltage (Note 3)	90-264 VAC or 127-370 VDC
Frequency	47-63 Hz
Current (Full load)	< 6.3 A max. (115 VAC) / < 3.15 A max. (230 VAC)
Inrush Current (<2ms)	Cold Start: < 40 A max. (115 VAC) / < 80 A max. (230 VAC)
Leakage Current	< 0.1 mA max. (Input-Output)
Power Factor (at 230 VAC)	PF > 0.94 at Full Load

[OUTPUT]	Value
Voltage Accuracy	$\pm$ 2%
Voltage Adj. Range	$\pm$ 4% Output Voltage
Line Regulation (115-264 VAC)	$\pm$ 0.5%
Load Regulation (10-100%)	$\pm$ 1% typ.
Minimum Load	3%
Auxiliary Output (Note 4)	12V / 0.3A; 0.1A minimum load
Hold-up Time (at 115 VAC) (Note 2)	8 ms min.
Standby Output	5V @ 1A (with fan) / 0.4A (without fan)

For quotes and customization requests, contact Digital Power sales at (877) 634-0982 or sales@digipwr.com.

## ELECTRICAL SPECIFICATIONS

[PROTECTION]	Value
Over Power Protection	Auto recovery
Over Voltage Protection	Auto recovery
Over Temperature Protection	Auto recovery
Short Circuit Protection	Protection level 1 (nominal): Continuous, Auto recovery; Protection level 2 (instantaneous high current): Latch

[ISOLATION]	Value
Input-Output (Note 5)	4000 VAC or 5656 VDC
Input-PE	2000 V
Output-PE	1500 V

[ENVIRONMENT]	Value
Operating Temperature	-30°C to +70°C (with derating)
Storage Temperature	-35°C to +85°C
Temperature Coefficient	±0.03%/°C (0~50°C); ±0.06%/°C (-30~0°C)
Altitude During Operation	5000m
Humidity	95% RH
Atmospheric Pressure	56 kPa to 106 kPa
MTBF	> 160,000 h @ 25°C (MIL-HDBK-217F)
Vibration	IEC60068-2-6 (10~500Hz, 2G 10min./1cycle, 60min. each along X, Y, Z axes)
Shock	IEC60068-2-27
Cooling Method	Free convection / 30 CFM FAN

[EMC]	Value
Conducted and Radiated EMI	EN55011 / conducted class B, Radiated Class A
EMS	EN60601-1-2 4th edition

[SAFETY APPROVAL]	Value
HDM5000/U/E-112, -124, -148	UL / IEC / EN 60601-1 Edition 3.1 & UL / IEC / EN 60950 AM2
HDM5000/U/E-115	UL / IEC / EN 60601-1 Edition 3.1

For quotes and customization requests, contact Digital Power sales at (877) 634-0982 or sales@digipwr.com.

# ELECTRICAL SPECIFICATIONS

## FUNCTION MANUAL & APPLICATION NOTE

- General Baseline: All specifications valid at normal input voltage, full load and +25°C after warm-up time unless otherwise stated.
- Note 1: Ripple & Noise are measured at 20MHz bandwidth with ceramic 0.1uF and chemi-con KY 47uF parallel capacitor. A 30cm twisted pair of no.18 AWG copper wire is connected to a 47uF and 0.1uF capacitor of proper polarity and voltage rating. The oscilloscope probe ground lead should connect directly to the probe ground ring and be as short as possible. Oscilloscope bandwidth should be 20MHz and connected to AC ground.
- Note 2: Hold-up Time measured at 90%  $V_{out}$ .
- Note 3: Please check the derating curve for more details.
- Note 4: Main  $V_{out}$  >3% load. 12V auxiliary output is 12V / 0.3A. 12V auxiliary output needs 0.1A minimum load. Auxiliary voltage output ground is 10.2~13.3V.
- Note 5: Strongly recommend conducting this test with DC voltage. If testing with AC voltage, disconnect all Y-capacitors from the Digital Power power supply.
- Note 6: Current Share Board (Optional): The output voltage difference of each parallel single element should be less than 0.2V. Output power at parallel operation = rated power per unit x number of units x 90%. Connect no more than 2 units in parallel. Contact Digital Power for advice if more than 2 units are needed. Minimum load should be 15%.
- Note 7: CAUTION: Double pole, neutral fusing. Disconnect mains before servicing.

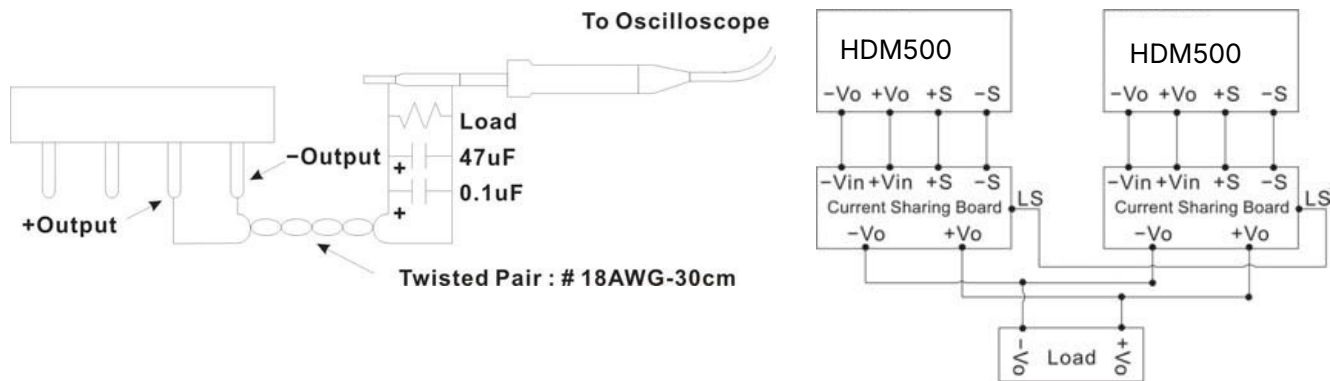

For quotes and customization requests, contact Digital Power sales at (877) 634-0982 or sales@digipwr.com.

# MECHANICAL DIMENSIONS

## FUNCTION MANUAL & APPLICATION NOTE

1. DC-OK Signal Between DC-OK and GND

	Output Status
3.7~6V	ON
0~1V	OFF

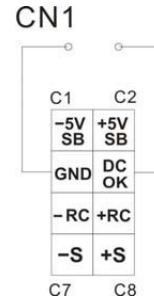
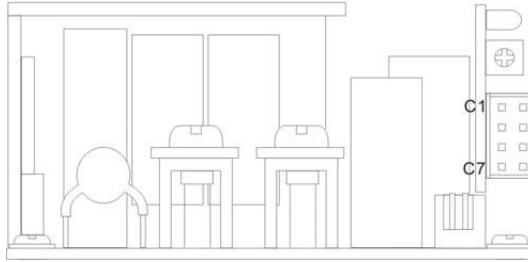

2. Remote Control can be turned ON/OFF by using the "Remote Control" function. Between +RC and -RC

	Output Status
SW ON (Short)	OFF
SW OFF (Open)	ON

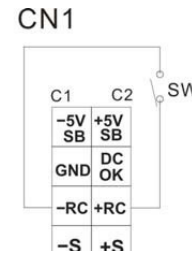
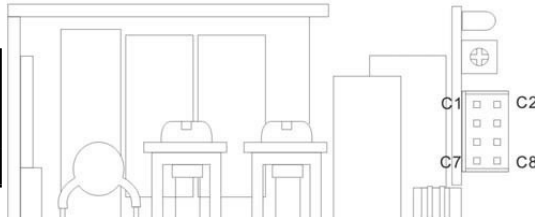

3. +S and -S Sense

Shorter wiring to each unit is recommended, as well as twisting +S and -S in pairs, as shown below

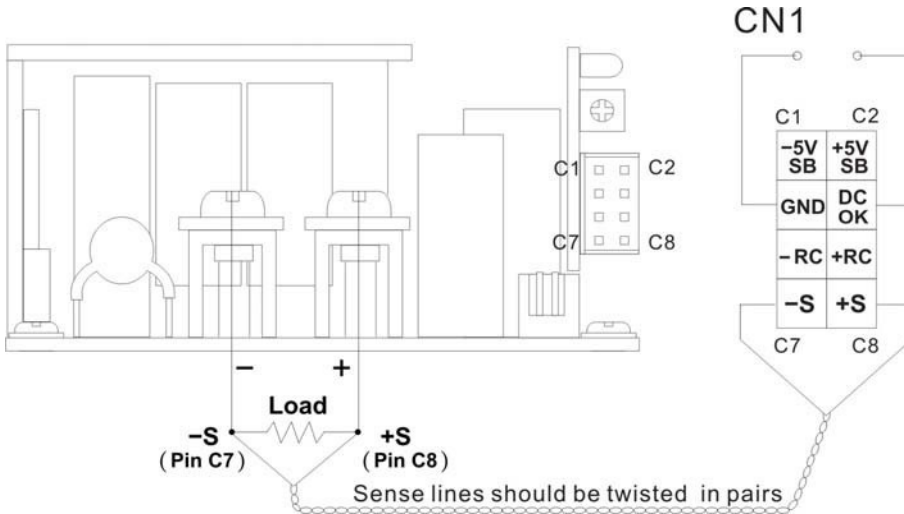

For quotes and customization requests, contact Digital Power sales at (877) 634-0982 or sales@digipwr.com.

# ELECTRICAL SPECIFICATIONS - HDM5000

## DERATING

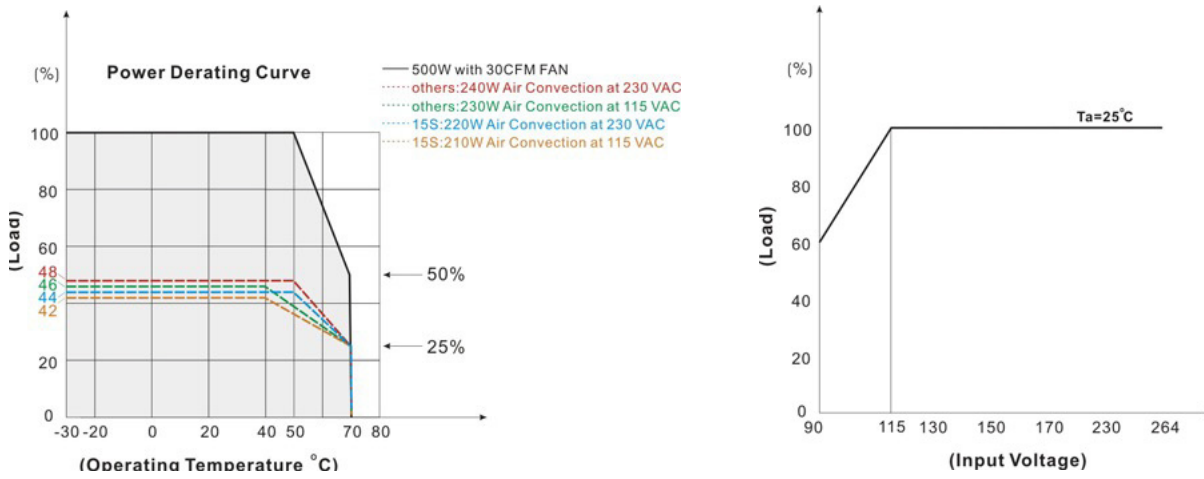

## BLOCK DIAGRAM

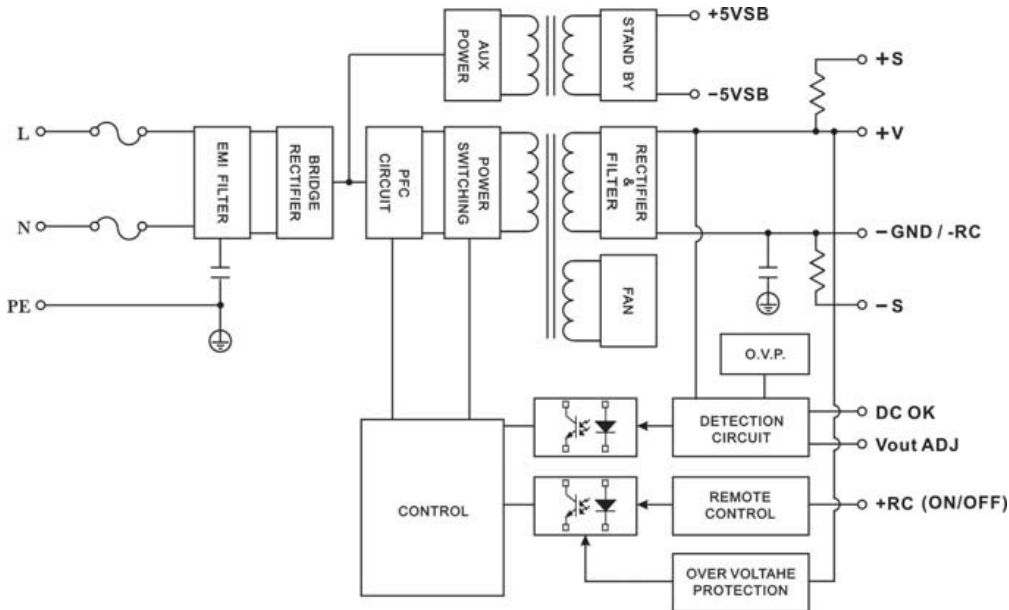

For quotes and customization requests, contact Digital Power sales at (877) 634-0982 or sales@digipwr.com.

# MECHANICAL DIMENSIONS - HDM5000

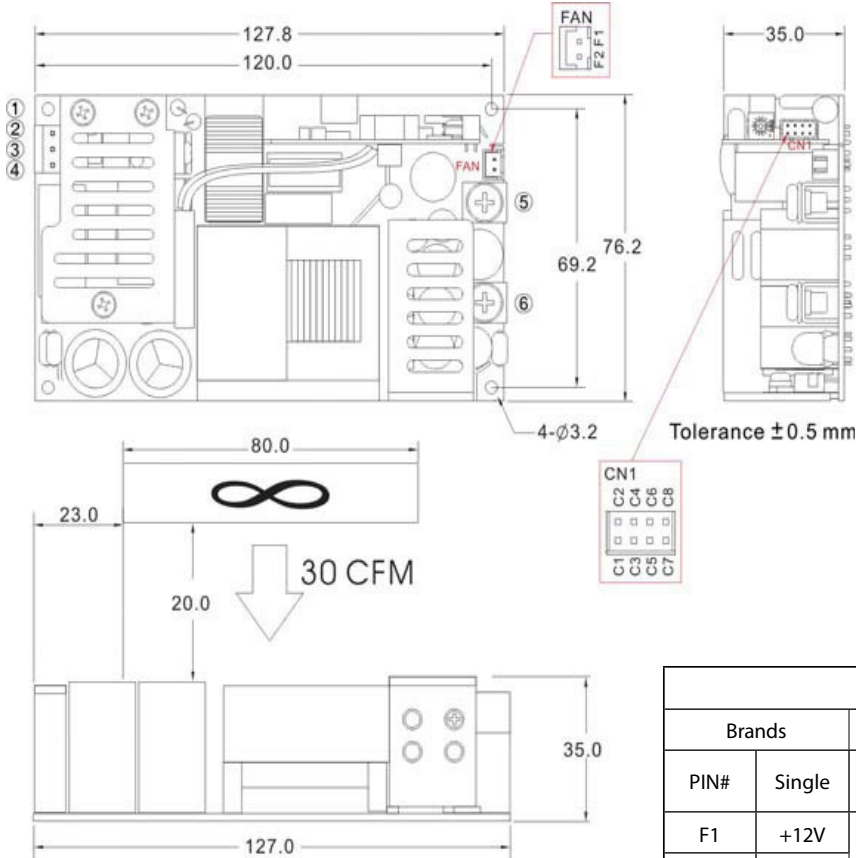

Connector Pin (FAN)					
Brands		Alex		JST	
PIN#	Single	Mating Housing	Terminal	Mating Housing	Terminal
F1	+12V	CX-H250-02	CX-T2501	XHP-2	SXH-002T-P0.6
F2	GND				

Brands		Alex		JST	
PIN#	Single	Mating Housing	Terminal	Mating Housing	Terminal
1	PE	—	—	—	—
2	AC IN (N)	9396-3	96T series	VHR-3N	SVH-41T-P1.1
3	NO PIN				
4	AC IN (L)	Terminal : M5 Pan HD screw in 2 positions. Torque to 8 lbs-in(90cNm) max			
5	+DC OUT				
6	-DC OUT				

Connector Pin (CN1)					
Brands		Cherng Weei		JST	
PIN#	Single	Mating Housing	Terminal	Mating Housing	Terminal
C1	-5V SB	PHD-H20-2X4P	PHD-T20	PHDR-08VS	SPHD-001T-P0.5
C2	+5V SB				
C3	GND				
C4	DC-OK				
C5	-RC				
C6	+RC				
C7	-S				
C8	+S				

For quotes and customization requests, contact Digital Power sales at (877) 634-0982 or sales@digipwr.com.

# MECHANICAL DIMENSIONS - HDM5000 with Current Share Function

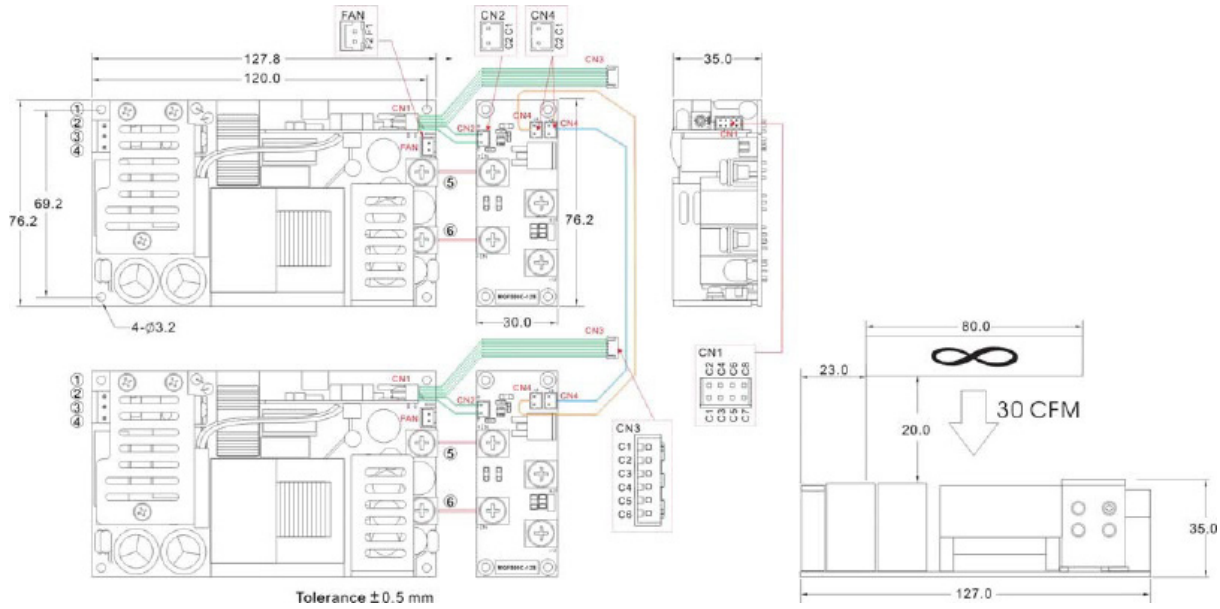

Brands		Alex		JST	
PIN#	Single	Mating Housing	Terminal	Mating Housing	Terminal
1	PE	—	—	—	—
2	AC IN (N)	9396-3	96T series	VHR-3N	SVH-41T-P1.1
3	NO PIN				
4	AC IN (L)				
5	+DC OUT	Terminal : M5 Pan HD screw in 2 positions. Torque to 8 lbs-in(90cNm) max			
6	-DC OUT				

Connector Pin (FAN)					
Brands		Alex		JST	
PIN#	Single	Mating Housing	Terminal	Mating Housing	Terminal
F1	+12V	CX-H250-02	CX-T2501	XHP-2	SXH-002T-P0.6
F2	GND				

Connector Pin (CN2)					
Brands		Cherng Weei		JST	
PIN#	Single	Mating Housing	Terminal	Mating Housing	Terminal
C1	-S	CP- H20-02	CP- T20B	PHR-2	SPH-002T-P0.5L
C2	+S				

Connector Pin (CN1)					
Brands		Cherng Weei		JST	
PIN#	Single	Mating Housing	Terminal	Mating Housing	Terminal
C1	-5V SB	PHD-H20-2X4P	PHD-T20	PHDR-08VS	SPHD-001T-P0.5
C2	+5V SB				
C3	GND				
C4	DC-OK				
C5	-RC				
C6	+RC				
C7	-S				
C8	+S				

For quotes and customization requests, contact Digital Power sales at (877) 634-0982 or sales@digipwr.com.

## MECHANICAL DIMENSIONS - HDM5000

Mating Housing Pin (CN3)					
Brands		Cherng Weei		JST	
PIN#	Single	Connector		Connector	
C1	-5V SB	CP-W20-06		B6B-PH-K-S	
C2	+5V SB				
C3	GND				
C4	DC-OK				
C5	-RC				
C6	+RC				

Connector Pin (CN4)					
Brands		Cherng Weei		JST	
PIN#	Single	Mating Housing	Terminal	Mating Housing	Terminal
C1	LS	CP-H20-02	CP-T20B	PHR-2	SPH-002T-P0.5L
C2	LS				

### FUNCTION DESCRIPITON of CN1 and CN3 (CN3 without C7 and C8 pin)

Pin No.	Function	Description
C1	-5VSB	This pin connects to the negative terminal(-V). Return for DC-OK and -RC signal output.
C2	+5VSB	Stand by voltage output ground 4.2~5.5V, referenced to pin C1(-5VSB). The maximum load current is 1A with Fan, 0.4A without Fan..
C3	GND	This pin connects to the negative terminal(-V). Return for DC-OK and -RC signal output.
C4	DC OK	DC-OK Signal is a DC output, referenced to pin C3(DC-OK GND).
C5	-RC	This pin connects to the negative terminal(-V). Return for DC-OK and -RC signal output.
C6	+RC	Turns the output on and off by electrical or dry contact between pin C5 (-RC), Short: Power OFF, Open: Power ON. The input voltage must be less than 1V in order to disable VOUT and greater than 3.3V (up to 5V) to enable it.
C7	-S	Negative sensing. The -S signal should be connected to the negative terminal of the load. The -S and +S leads should be twisted in pair to minimize noise pick-up effect.
C8	+S	Positive sensing. The +S signal should be connected to the positive terminal of the load. The +S and -S leads should be twisted in pair to minimize noise pick-up effect.

For quotes and customization requests, contact Digital Power sales at (877) 634-0982 or sales@digipwr.com.

# ELECTRICAL SPECIFICATIONS - HDM500U

## DERATING

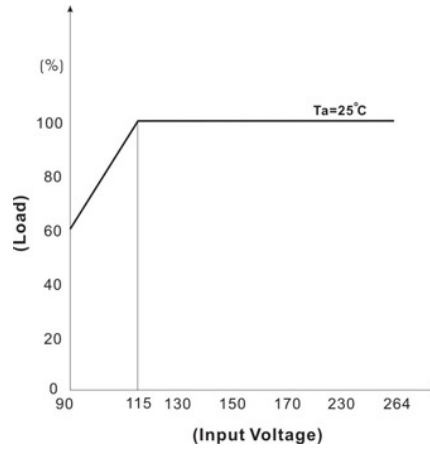
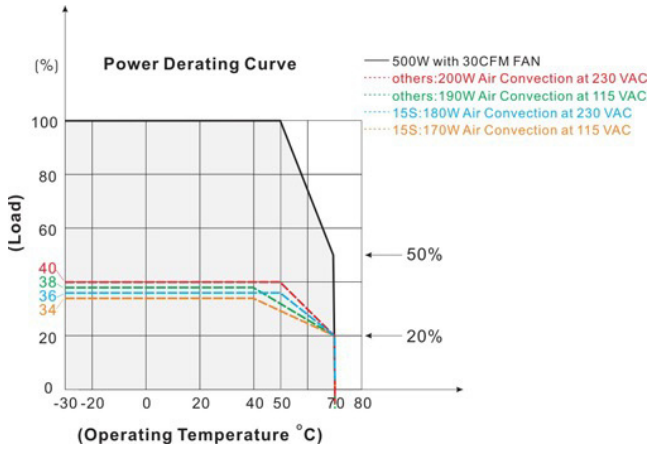

## BLOCK DIAGRAM

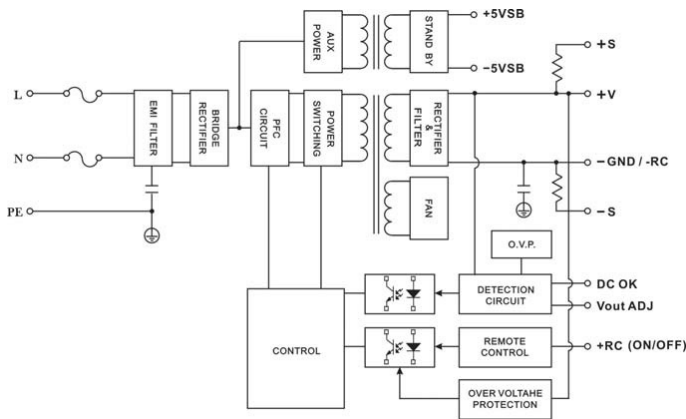

For quotes and customization requests, contact Digital Power sales at (877) 634-0982 or sales@digipwr.com.

# MECHANICAL DIMENSIONS - HDM500U

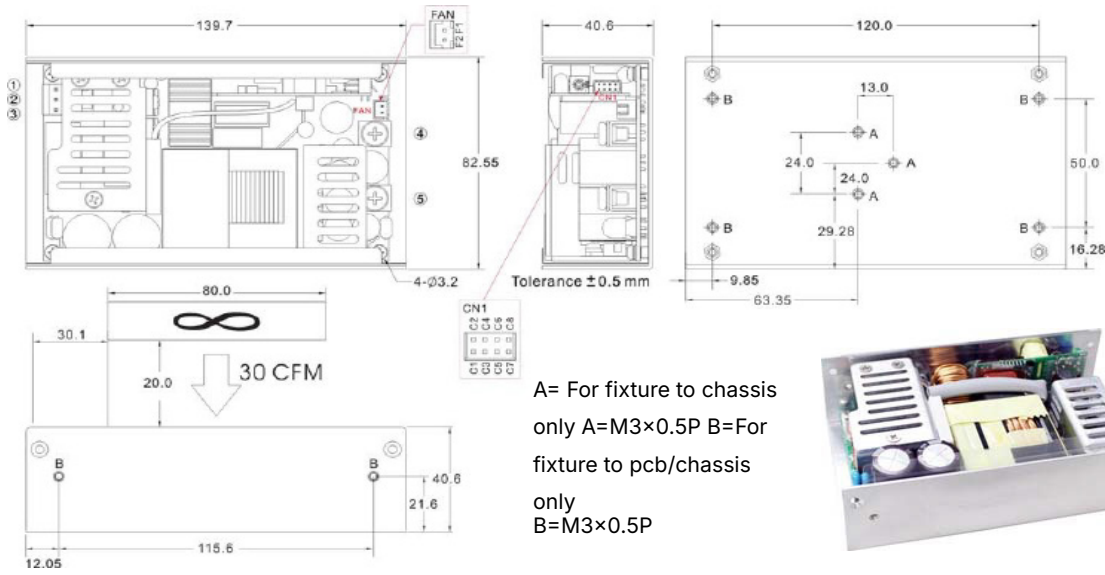

Brands		Alex		JST	
PIN#	Single	Mating Housing	Terminal	Mating Housing	Terminal
A,B	PE	—	—	—	—
1	AC IN (N)	9396-3	96T series	VHR-3N	SVH-41T-P1.1
2	NO PIN				
3	AC IN (L)				
4	+DC OUT	Terminal : M5 Pan HD screw in 2 positions. Torque to 8 lbs-in(90cNm) max			
5	-DC OUT				

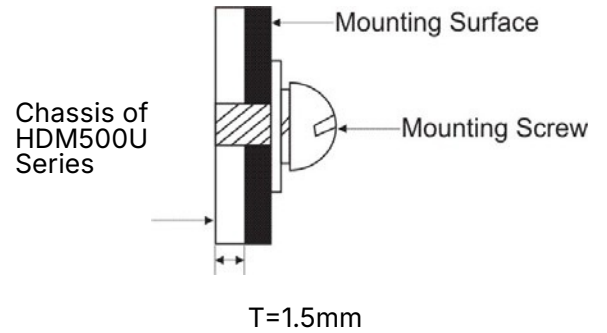

Connector Pin (CN1)					
Brands		Cherng Weei		JST	
PIN#	Single	Mating Housing	Terminal	Mating Housing	Terminal
C1	-5V SB	PHD-H20-2X4P	PHD-T20	PHDR-08VS	SPHD-001T-P0.5
C2	+5V SB				
C3	GND				
C4	DC-OK				
C5	-RC				
C6	+RC				
C7	-S				
C8	+S				

Connector Pin (FAN)					
Brands		Alex		JST	
PIN#	Single	Mating Housing	Terminal	Mating Housing	Terminal
F1	+12V	CX-H250-02	CX-T2501	XHP-2	SXH-002T-P0.6
F2	GND				

For quotes and customization requests, contact Digital Power sales at (877) 634-0982 or sales@digipwr.com.

# MECHANICAL DIMENSIONS - HDM500U with Current Share Function

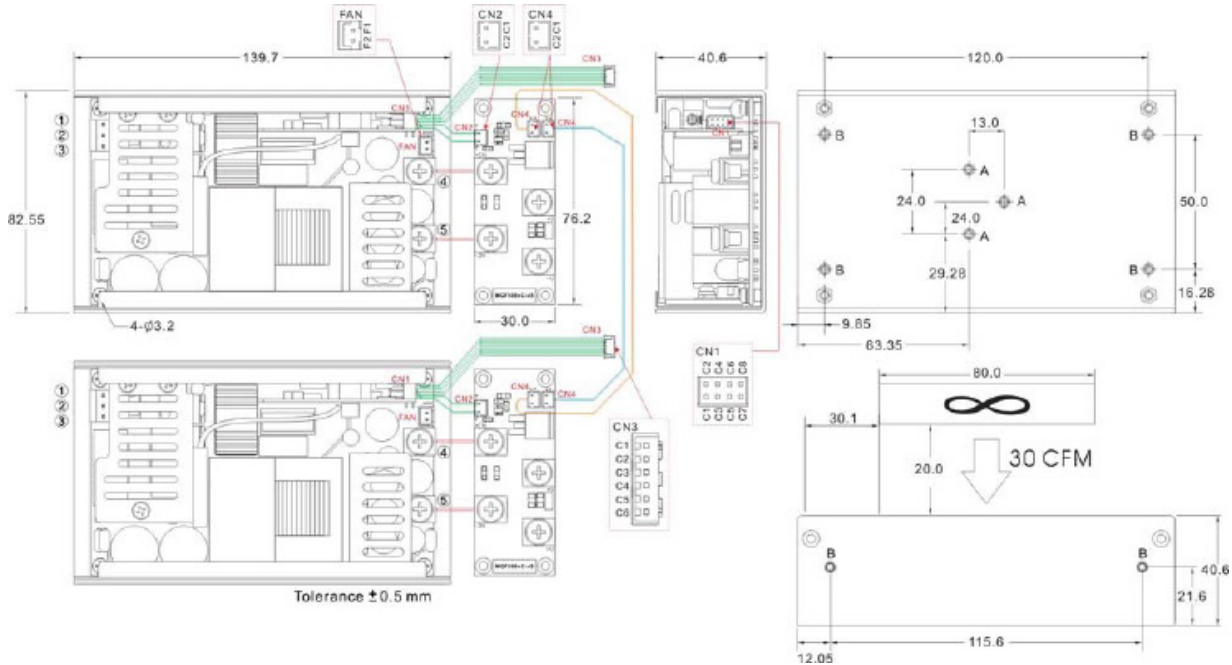

A= For fixture to chassis only  
 A=M3×0.5P  
 B=For fixture to pcb/chassis only B=M3×0.5P

ASSEMBLY INSTRUCTIONS  
 U Case T=1.5mm  
 Customer is advised to screw into the threads no more than 1.5mm

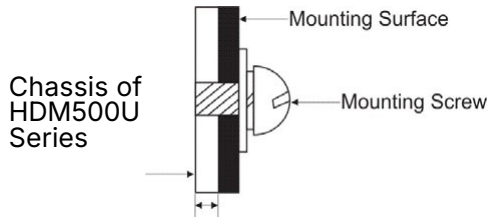

T=1.5mm

Brands		Alex		JST	
PIN#	Single	Mating Housing	Terminal	Mating Housing	Terminal
A.B	PE	—	—	—	—
1	AC IN (N)	9396-3	96T series	VHR-3N	SVH-41T-P1.1
2	NO PIN				
3	AC IN (L)	Terminal : M5 Pan HD screw in 2 positions. Torque to 8 lbs-in(90cNm) max			
4	+DC OUT				
5	-DC OUT				

Connector Pin (FAN)					
Brands		Alex		JST	
PIN#	Single	Mating Housing	Terminal	Mating Housing	Terminal
F1	+12V	CX-H250-02	CX-T2501	XHP-2	SXH-002T-P0.6
F2	GND				

For quotes and customization requests, contact Digital Power sales at (877) 634-0982 or sales@digipwr.com.

## MECHANICAL DIMENSIONS - HDM500U and HDM500E

Connector Pin (CN1)					
Brands		Cherng Weei		JST	
PIN#	Single	Mating Housing	Terminal	Mating Housing	Terminal
C1	-5V SB	PHD-H20-2X4P	PHD-T20	PHDR-08VS	SPHD-001T-P0.5
C2	+5V SB				
C3	GND				
C4	DC-OK				
C5	-RC				
C6	+RC				
C7	-S				
C8	+S				

Mating Housing Pin (CN3)			
Brands		Cherng Weei	JST
PIN#	Single	Connector	Connector
C1	-5V SB	CP-W20-06	B6B-PH-K-S
C2	+5V SB		
C3	GND		
C4	DC-OK		
C5	-RC		
C6	+RC		

Connector Pin (CN2)					
Brands		Cherng Weei		JST	
PIN#	Single	Mating Housing	Terminal	Mating Housing	Terminal
C1	-S	CP-H20-02	CP-T20B	PHR-2	SPH-002T-P0.5L
C2	+S				

Connector Pin (CN4)					
Brands		Cherng Weei		JST	
PIN#	Single	Mating Housing	Terminal	Mating Housing	Terminal
C1	LS	CP-H20-02	CP-T20B	PHR-2	SPH-002T-P0.5L
C2	LS				

### FUNCTION DESCRIPTION of CN1 and CN3 (CN3 without C7 and C8 pin)

Pin No.	Function	Description
C1	-5VSB	This pin connects to the negative terminal(-V). Return for DC-OK and -RC signal output.
C2	+5VSB	Stand by voltage output ground 4.2~5.5V, referenced to pin C1(5VSB). The maximum load current is 1A with Fan, 0.4A without Fan..
C3	GND	This pin connects to the negative terminal(-V). Return for DC-OK and -RC signal output.
C4	DC OK	DC-OK Signal is a DC output, referenced to pin C3(DC-OK GND).
C5	-RC	This pin connects to the negative terminal(-V). Return for DC-OK and -RC signal output.
C6	+RC	Turns the output on and off by electrical or dry contact between pin C5 (-RC), Short: Power OFF, Open: Power ON. The input voltage must be less than 1V in order to disable VOUT and greater than 3.3V (up to 5V) to enable it.
C7	-S	Negative sensing. The -S signal should be connected to the negative terminal of the load. The -S and +S leads should be twisted in pair to minimize noise pick-up effect.
C8	+S	Positive sensing. The +S signal should be connected to the positive terminal of the load. The +S and -S leads should be twisted in pair to minimize noise pick-up effect.

For quotes and customization requests, contact Digital Power sales at (877) 634-0982 or sales@digipwr.com.

# ELECTRICAL SPECIFICATIONS - HDM500E

## DERATING

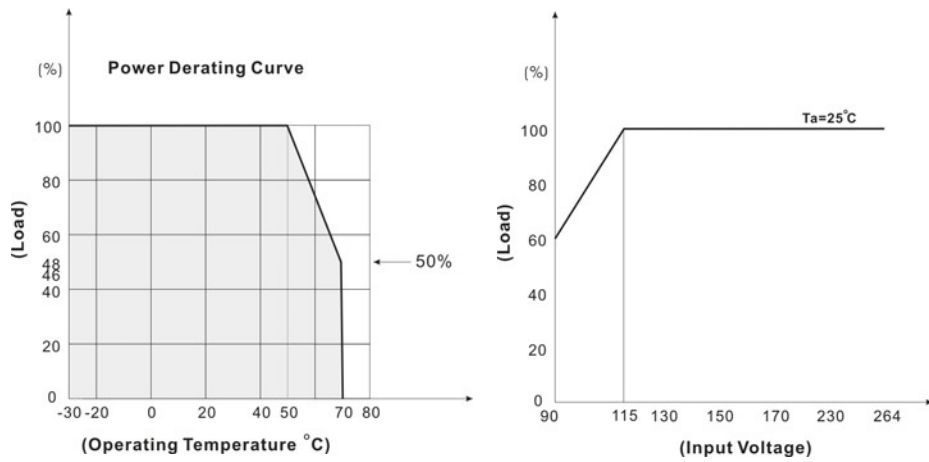

## BLOCK DIAGRAM

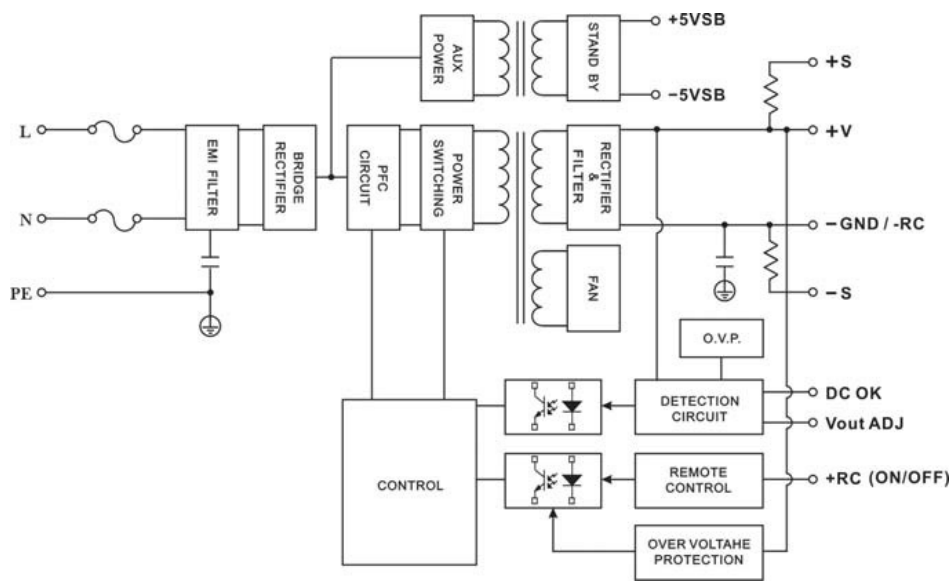

For quotes and customization requests, contact Digital Power sales at (877) 634-0982 or sales@digipwr.com.

# MECHANICAL DIMENSIONS - HDM500E

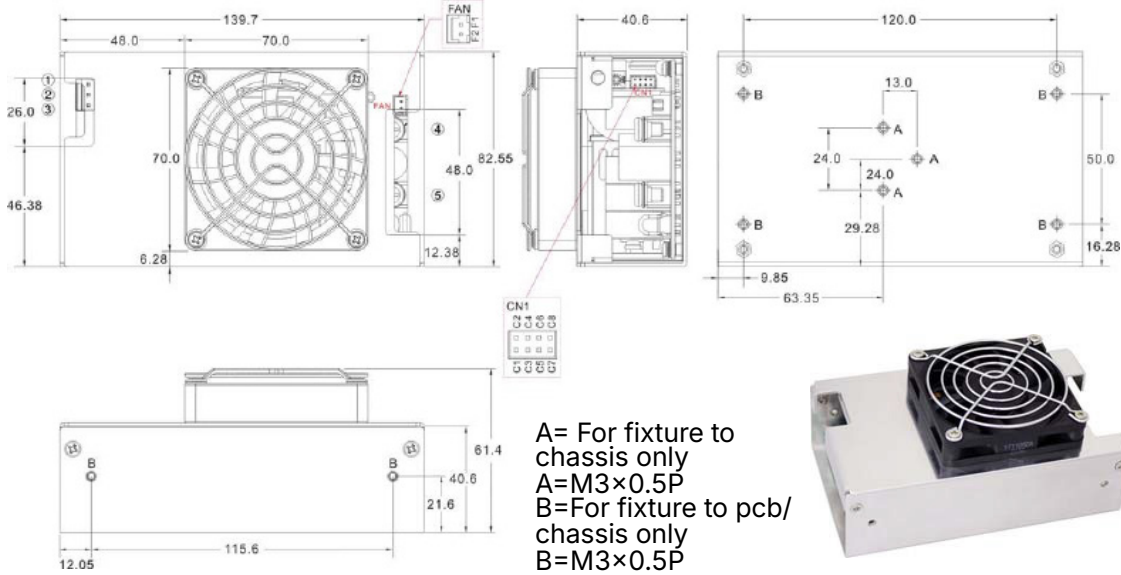

Brands		Alex		JST	
PIN#	Single	Mating Housing	Terminal	Mating Housing	Terminal
A,B	PE	—	—	—	—
1	AC IN (N)	9396-3	96T series	VHR-3N	SVH-41T-P1.1
2	NO PIN				
3	AC IN (L)				
4	+DC OUT	Terminal : M5 Pan HD screw in 2 positions. Torque to 8 lbs-in(90cNm) max			
5	-DC OUT				

**ASSEMBLY INSTRUCTIONS**  
 U Case T=1.5mm  
 Customer is advised to screw into the threads no more than 1.5mm

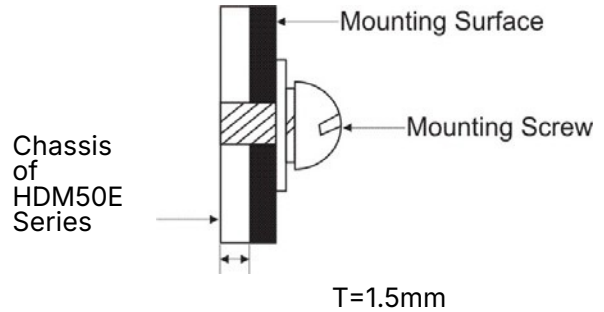

Connector Pin (CN1)					
Brands		Cherng Weei		JST	
PIN#	Single	Mating Housing	Terminal	Mating Housing	Terminal
C1	-5V SB	PHXD-H20-2X4P	PHD-T20	PHDR-08VS	SPHD-001T-P0.5
C2	+5V SB				
C3	GND				
C4	DC-OK				
C5	-RC				
C6	+RC				
C7	-S				
C8	+S				

Connector Pin (FAN)					
Brands		Alex		JST	
PIN#	Single	Mating Housing	Terminal	Mating Housing	Terminal
F1	+12V	CX-H250-02	CX-T2501	XHP-2	SXH-002T-P0.6
F2	GND				

For quotes and customization requests, contact Digital Power sales at (877) 634-0982 or sales@digipwr.com.

# MECHANICAL DIMENSIONS - HDM500E with Current Share Function

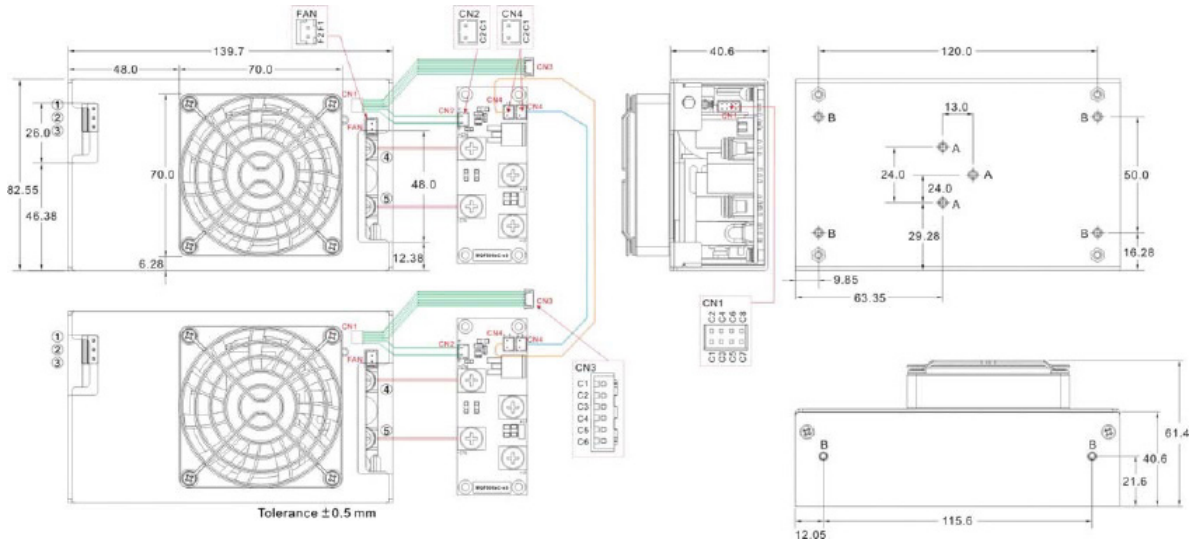

A= For fixture to chassis only  
 A=M3×0.5P  
 B=For fixture to pcb/chassis only  
 B=M3×0.5P

ASSEMBLY INSTRUCTIONS U Case  
 T=1.5mm Customer is advised to screw into the threads no more than 1.5mm

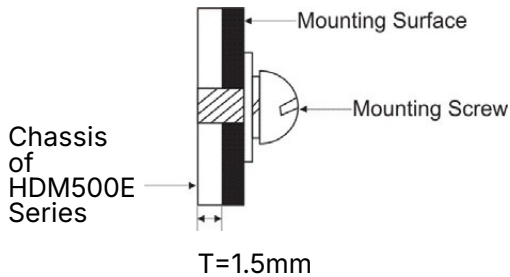

Brands		Alex		JST	
PIN#	Single	Mating Housing	Terminal	Mating Housing	Terminal
A,B	PE	—	—	—	—
1	AC IN (N)	9396-3	96T series	VHR-3N	SVH-41T-P1.1
2	NO PIN				
3	AC IN (L)				
4	+DC OUT	Terminal : M5 Pan HD screw in 2 positions. Torque to 8 lbs-in(90cNm) max			
5	-DC OUT				

Connector Pin (FAN)					
Brands		Cherng Weei		JST	
PIN#	Single	Mating Housing	Terminal	Mating Housing	Terminal
F1	+12V	CX-H250-02	CX-T2501	XHP-2	SXH-002T-P0.6
F2	GND				

For quotes and customization requests, contact Digital Power sales at (877) 634-0982 or sales@digipwr.com.